

GVM

GVM Z100B

CONTENTS

Important Safety Instructions	Page 1~2
Warning	Page 2
Product Introduction	Page 3
Product Parameter	Page 4
Disclaimers	Page 4
Product Structure Diagram	Page 5
Installation Method	Page 6~12
Description Of Product Control Keys	Page 13
Function Introduction & Instructions For Use	Page 14~15
APP Control	Page 16~17
Use And Preservation	Page 17
Quick Troubleshooting	Page 18
Packing List	Page 19
Precautions	Page 19
Product Warranty	Page 20~21

IMPORTANT SAFETY INSTRUCTIONS

This product is professional lighting and staging equipment and should only be operated by a qualified lighting technician or used under the supervision of a professional. Always follow the precautions below to ensure safe and proper usage.





1. Read the product manual carefully before use.
2. This product is only suitable to use in a temperature range of -20°C to 45°C.
3. Do not place the equipment near flammable and volatile solvents such as alcohol and gasoline.
4. Before storing the device, make sure it has cooled down completely. When being stored, unplug the power cord from the device. The equipment should be stored in its carrying case or a well-ventilated and dry place.
5. This lighting fixture is not for general illumination and should not be used as such. Individuals with eye injuries or sensitivity should avoid using this lighting fixture.
6. This is a professional light and children are prohibited from using it. Parents or guardians must closely supervise children when they are near the equipment to prevent personal injury caused by colliding with or misusing the equipment.
7. Before using the equipment, please remove the protective cover.
8. When the lighting fixture is on, it is forbidden to stare directly at the light source under any circumstances. High-intensity lighting should only be used under the guidance of a professional lighting technician. Avoid staying in a high-intensity light environment for a long time. If feeling any discomfort, please immediately turn off the lighting fixture, and seek medical attention.
9. When the lighting fixture is on, use it carefully and avoid contacting high-temperature components such as LED light sources to prevent being burnt.
10. Do not use damaged equipment or accessories. Wait for a professional repairman to inspect and repair it before it is confirmed that the equipment can function normally.
11. If the light source is damaged or deformed due to heat, please stop using it and contact the manufacturer, service agents, or qualified repairman promptly to replace the light source to avoid accidents.
12. If the product is cracked due to falling, squeezing, or strong impact during use, please stop use it to avoid being electrically shocked by touching internal electronic components.
13. Do not disassemble the product by yourself. If the product malfunctions, it must be checked and repaired by the manufacturer or authorized repair personnel.
14. Before cleaning and maintenance, be sure to unplug the power supply. To unplug never pull on the cable but always pull the plug itself. This device shall only operate with earthed power outlets or emergency power generators.
15. When cleaning the device, do not wipe it with a wet cloth. Use a dry and soft cloth to wipe off the dirt.
16. If an extension cord is required, it needs to have the necessary capacity to power the respective unit. Using an extension cord with a lower current capacity than the devices need may cause overheating.

17. For some products with long power cords, please place the power cords properly and avoid contact with overheated surfaces that may damage or trip personnel. Please use the original power cords of our manufactory. The damage caused by using non-original power cords is not covered by our repair service.
18. Do not use product accessories that are not recommended by our brand to avoid fire, electric shock, or personal injury.
19. Some products use batteries for power supply. Do not use any batteries, power sources, or accessories that are not specified in the user manual. Please keep batteries and other accessories out of reach of children and infants. If a child or infant swallows a battery or accessory, seek medical attention immediately. If the battery leaks, changes color, deforms, smokes, or emits an odor, remove it immediately. Be careful not to get burned during the removal. Continued use of such batteries may cause a fire, electric shock, or skin burns. Do not use any deformed or modified batteries. Do not disassemble or modify this product or the battery. Do not heat the battery or solder it. Do not let the battery come into contact with fire or water, or subject it to strong external force. Do not insert the battery's positive and negative ends incorrectly, or mix and use old and new batteries or different types of batteries.
20. For some products with built-in lithium batteries, please use a dedicated charger for charging, and following the correct operating instructions within the prescribed voltage and temperature range.
21. The warranty last for one year. Consumables like batteries, adapters, power cords, and other accessories are not covered by the warranty.
22. The one-year warranty will be invalidated if the equipment is found to have been repaired privately. The related repair costs will be charged.
23. Equipment malfunctions caused by non-standard operations are not covered by the warranty.
24. The safety instructions are based on our factory's strict testing. If there are any changes in the equipment's design and specifications, we reserve the right not to notify you. Customers can visit our official website to check the latest digital version of the instructions and learn about the newest product information.

Keep these instructions!



WARNING:

-  High-power LED lights are strictly prohibited from being directly viewed or shining into other people's eyes.
-  Do not unplug the power cord or connecting wires while the light is on to avoid personal injury.
-  Do not cover the heat dissipation port when the lamp is in operation.
-  Keep children away from touching or using this light.
-  As professional lighting equipment, please make sure to operate it correctly according to the user manual.

PRODUCT INTRODUCTION

Thank you for purchasing the “GVM Z100B”. This product is specifically designed for advanced photography and videography professionals. It is suitable for live stream / broadcast / film production / photography and also ideal for YouTube video production.

The main features of the product are:

1. Equipped with 450 individual LED beads, it features bi-color temperatures output ranging from 2700 to 6800K, allowing step-less light intensity adjustment. The LED beads has an impressive color rendering index rating of over 95, it can help restore and enrich the natural colors of your subject, delivers lifelike and vibrant shooting results.
2. APP control: This light can be controlled via your IOS/Android smart mobile devices; as well as be group controlled along with other GVM brand devices that support Bluetooth mesh networking.
3. Light's brightness and color temperature can be adjusted using the remote controller.
4. Types of lighting modes: CCT mode, Source Matching mode (Only accessible through the APP), and Effects mode (Only accessible through the APP).
 - CCT Mode: Allows you to adjust both brightness and color temperature for optimal lighting control.
 - Source Matching Mode: **This mode can only be accessed through the APP.** Choose from 12 simulated light sources: Tungsten, HMI5600, HMI6000, Studio Lamps, Sodium Lamp, Halogen, Arc Lamp, Candle, Sunset/Sunrise, Daylight, Overcast Sky, and CFL Cool White..
 - Effects Mode: **ercast Sky, and CFL Cool White.**
 - **Effects Mode: This mode can only be accessed through the APP or the YK22 remote controller.** Choose from 12 simulated light effects: Lightning, CCT Loop, Candle, Bad Bulb, TV, Paparazzi, Explosion, Pulsing, Strobe, Fire, Fireworks, and Welding.
5. Innovatively designed with heavy-duty zippers integrated on all edges of the unit. Allowing you to expand your lighting coverage by simply connecting two or multiple units of lights to tailor your setup for any shooting environment.

We firmly believe that, proper use of this product will greatly enhance your production workflow. We strongly recommend reading the following user guide carefully before using this product.

PRODUCT PARAMETER

- ◆ Brand : GVM
- ◆ Product Model : GVM Z100B
- ◆ Product Name : ZipTile 100B
- ◆ Product Type : LED Light Mat
- ◆ Features : Expandable design, All-new LCD screen, High CRI rated LED Chips.
- ◆ Control Methods : COn-Board Controls, App Control via Bluetooth Mesh Networking, Infrared remote controller.
- ◆ Bluetooth Controllable Distance : ≤50M
- ◆ Color Rendering Index : ≥95
- ◆ Color Temperature Range : 2700K~6800K
- ◆ Illuminance : Bare bulb 9510 lux@0.5m, 2560 lux@1m;
Light with included Diffusion 4680 lux@0.5m, 1340 lux@1m
- ◆ Light Adjustment Method : Step-less adjustment
- ◆ LED Chip Quantity : 450 pieces
- ◆ Power : 100 W
- ◆ Product Net Weight : 0.95 kg
- ◆ Product Size (mm) : 300×300×26
- ◆ Power Supply Method : DC Input & Battery(Batteries need to be purchased separately)
- ◆ Power Supply : 32V/3.5A
- ◆ Adapter operating voltage : AC100V~240V
- ◆ Cooling : Passive heat dissipation
- ◆ Product Material : Aluminum alloy, Engineering thermoplastic & Fabric
- ◆ Commodity Origin : Huizhou. China

DISCLAIMERS

1. Before using this product, please read the text carefully to ensure that the correct operation of the product has been carried out. Failure to follow and not following the instructions and warnings in this document may cause harm to you and others around you, or even damage the product or other surrounding items.
2. By using this product, you are deemed to have carefully read the disclaimer and warning, understand and acknowledge all the terms and contents of this statement, and promise to take full responsibility for the use of this product and the possible consequences.
3. Design and specifications are subject to change without notice.

PRODUCT STRUCTURE DIAGRAM

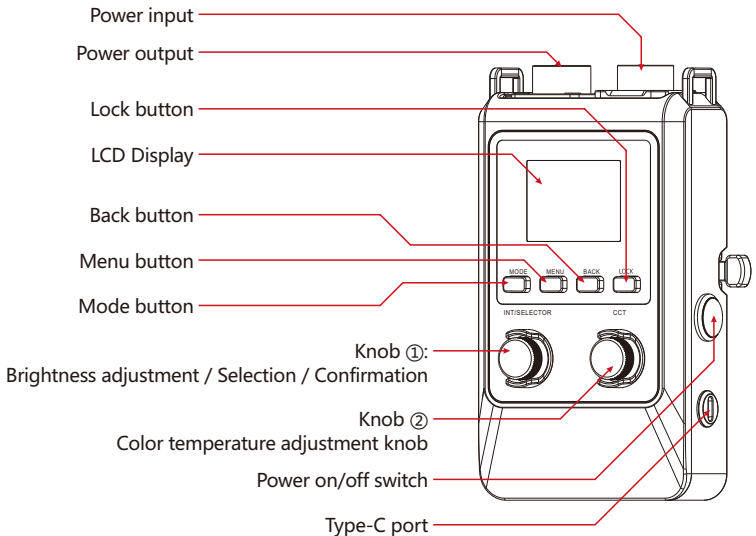
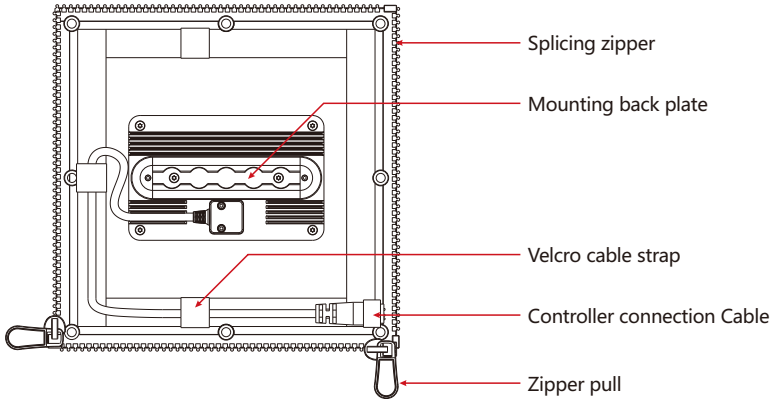

INSTALLATION METHOD

1 Product component overview.

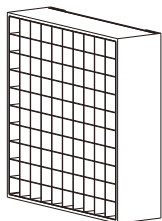

Light Control Skirt & Grid

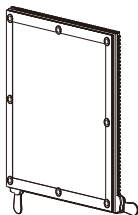

ZipTile Z100B



Rail-Mount Baby Pin Adapter



V-Mount Rail Engagement Bracket



Swivel Yoke Mount



Controller



Power Adapter

2 Installing the Softbox

1. Position the light control skirt frame so its edges align with the front frame of the light. Use the built-in Velcro strips, to fasten the skirt frame securely to the light body. Ensure all sides are firmly attached to prevent light leaks. The skirt should sit flush with the light's front frame and be stable when lightly pulled.
2. Stretch the diffusion cloth evenly over the inner edge of the skirt frame. Fasten the edges using the Velcro strips. Make sure the fabric is smooth to avoid uneven light patterns.
3. Place the grid over the front of the skirt frame, aligning it with the Velcro stripe. Press firmly along all sides so the grid is fully attached and flush with the frame.

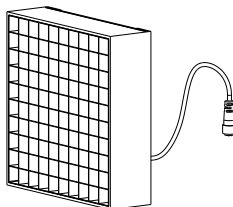
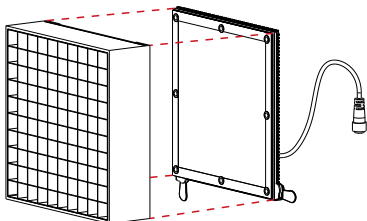

3 Bracket installation

Press and pull back the back buckle pressure plate first → Then insert the bracket into the slots of the mounting rail → Move the bracket to the narrow part of the groove → Tighten the knob and secure the bracket to the installation slot.



V-Mount Rail Engagement Bracket

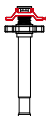
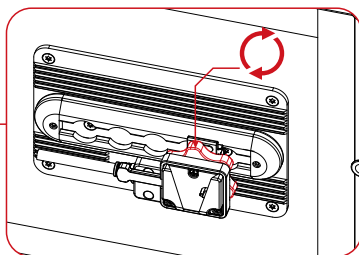
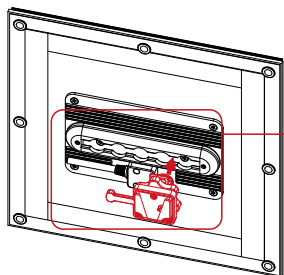
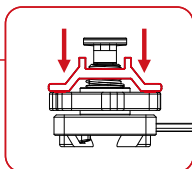

Rail-Mount Baby Pin Adapter

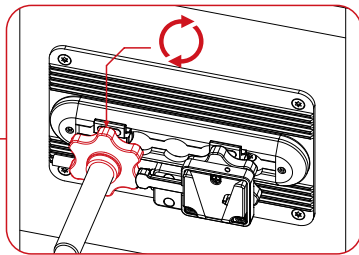
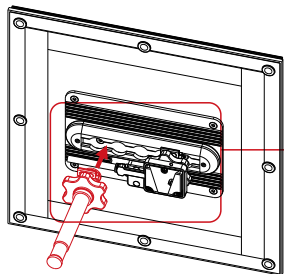
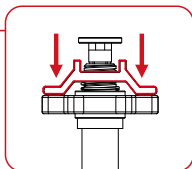

4 Mounting and dismounting of the control box.

Installation :

Align the V-mount clip on the side of the controller with the v mount bracket and slide it down into the slot to secure it in place.

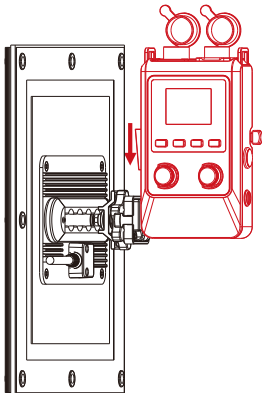

Dismounting :

Press in the V-lock release lever → Push the controller to dismount.

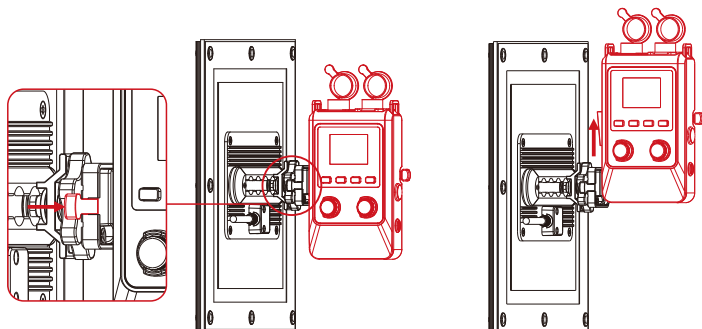

5 Installing the Swivel Yoke Mount

1. Hold the swivel yoke mount so its open clamp section aligns with the locking support rod already fixed on the light's back plate. Ensure the clamp is oriented in the desired tilt direction before securing.
2. Slide the mount fully onto the locking support rod until it is seated against the stop point. The mount's clamp should completely encircle the rod for a stable fit.
3. Turn the clamp's locking handle clockwise until it is snug. Ensure there is no wobble. If needed, slightly reposition and re-tighten.

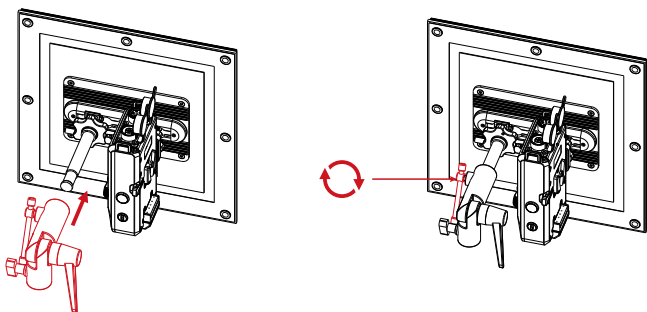

6 Mounting the light onto a light stand

1. Position the swivel yoke mount's receiver directly above the stand's spigot. Make sure the mount's tightening knob is loosened enough to fit over the spigot, but not fully removed.
2. Lower the light and mount assembly straight down onto the spigot until fully seated. The mount should fit snugly over the spigot without excessive force.
3. Turn the mount's locking knob clockwise to tighten it onto the spigot. Doublecheck that the light is firmly fixed and cannot rotate or slip.

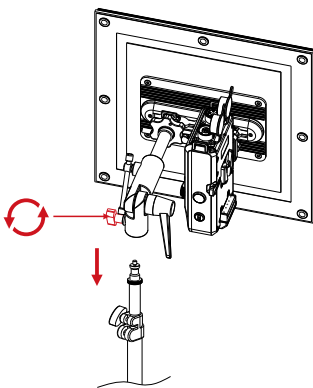

7 Tilt Angle adjustment

Loosen the angle locking handle on the side of the Swivel Yoke Mount then adjust the tilt angle of the light to your needs, and then tighten the angle locking handle.

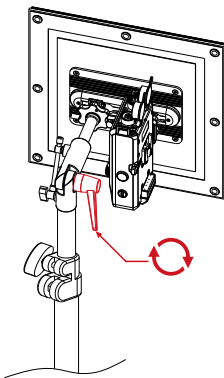

8 Connecting the light to the controller

Align the connector on the head cable from the light with the output port on the controller. Insert the connector fully until it clicks then engage the twist lock mechanism to achieve a secured connection.

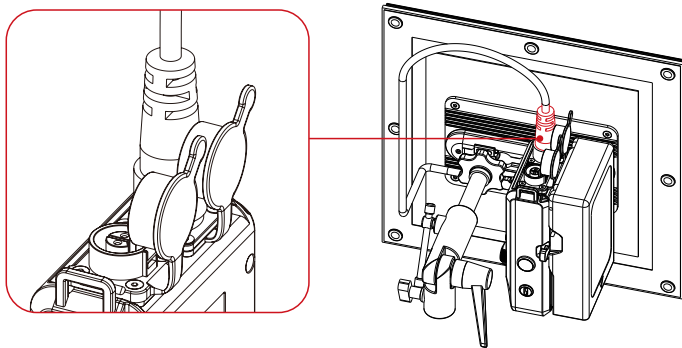

9 Power Supply Options

This fixture supports two power supply modes:

1. DC Power Input – Operates via the included DC power adapter.
2. V-Mount Battery – Compatible with standard V-Mount batteries for portable, on-location use. (Batteries need to be purchased separately.)

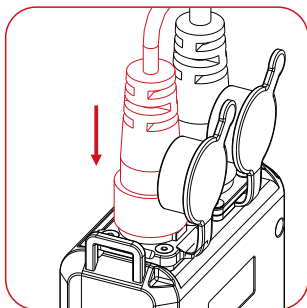

DC Powerinput

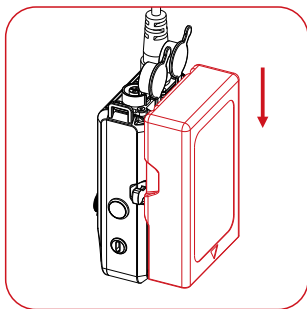
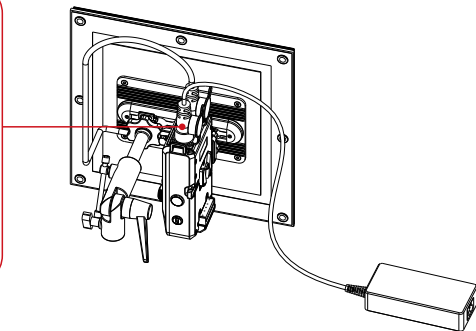

V-mount Batteryslot

(Batteriesneedtobepurchasedseparately)

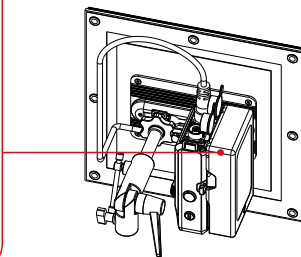

- 10** When storing the light, use the Velcro straps to secure the cable to the back of the fixture. This helps prevent tangling, protects the connector, and keeps the unit organized for transport.

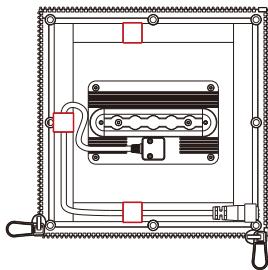

- 11** When using two or more Z100B fixtures, you can connect them together using the zipper-edge design around the lights. This allows multiple units to be seamlessly linked, creating a larger and more versatile lighting setup.

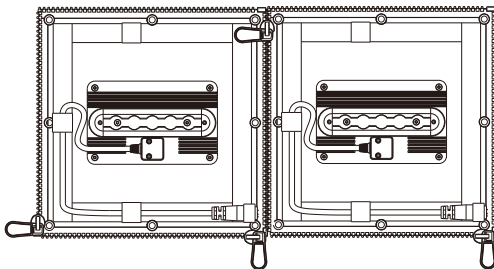





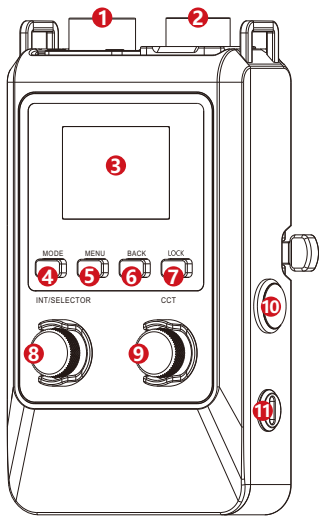



DESCRIPTION OF PRODUCT CONTROL KEYS

- 1** Power output:
Used to connect the cable from the light.
- 2** Power input:
Used to connect the cable from the DC power adapter.
- 3** LCD display:
Display current settings, modes and parameters.
- 4** Mode button:
Press this button to enter the Colortemperature and brightness adjustmentmode.
- 5** Menu button:
Press this button to enter the menu page.
- 6** Return button:
Press this button to return to theprevious page.
- 7** Lock button:
Press and hold for 3 seconds to lock the display interface to the light mode interface, and the light parameters cannot be adjusted through the knob.Press and hold for 3 seconds in the locked state to unlock.
- 8** Knob 1:
Intensity adjustment knob/Multi-functional knob.
【Rotate knob 1】 to go through selections in the menu page / change parameters / adjust brightness level.
【Short press knob 1】 to confirm the selection/ enter a setting page.
- 9** Knob 2:
Color temperature adjustment knob.
【Rotate knob 2】 to adjust the output color temperature from 2700K-6800K.
- 10** ON/OFF switch:
Turn on or off the light.
- 11** TYPE-C port:
Support firmware update and data transmission.
(Does not support power pass through to the product or charging of mobile phonesand other digital products externally.)



FUNCTION INTRODUCTION & INSTRUCTIONS FOR USE

④ Status Indication Specification

	Bluetooth connected		Dimming curve: Linear
	Remote control		Dimming curve: Exp
	The device is disconnected		Dimming curve: Log
	Power supplied via DC connection		Dimming curve: S
	Power supplied via battery		

① CCT Mode

Press the [MODE] key to enter the CCT mode.

INT: Indicates current light's intensity parameter: Rotate [Knob 1] to adjust the intensity of the light; Short pressing [Knob 1] allows for quick adjustment of light intensity at 25% increments.

CCT: Indicates current light's color temperature parameter, Rotate [Knob 2] to adjust the color temperature from 2700K-6800K.

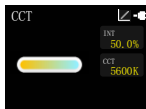

② Menu Page

Press the [MENU] button to enter the menu page. Rotate [Knob 1] to go through settings. Short press [Knob 1] to enter the corresponding sub-menu page → Short press or rotate [Knob 1] to confirm selection or change parameters → Press [BACK] button once to return to the previous menu page.

DIM CURVE:

Light dimming curve determines how the light's brightness changes in response to adjustments made on the dimmer knob. Select from the 4 different dimming curve [Linear/Log/Exp/S] base on your needs.

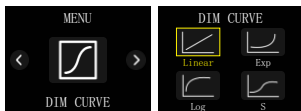

WL SETTINGS:

RF Settings: Switch ON/OFF the radio frequency and change channel parameters.

BT Settings: Switch ON/OFF the Bluetooth function and perform Bluetooth reset.

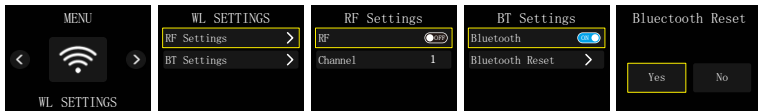

LANGUAGE:

Change system language [English/Chinese] displayed on the screen.

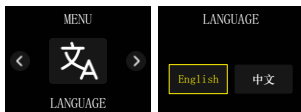

SYSTEM SETTINGS:

Products: View system firmware information.

System Reset: Restore factory settings.



⑤ Source matching

Light source matching mode can only be accessed through the APP. This mode offers 12 kinds of light sources commonly used on a film set: Tungsten, HMI5600, HMI6000, Studio Lamps, Sodium Lamp, Halogen, Arc Lamp, Candle, Sunset/Sunrise, Daylight, Overcast Sky, and CFL Cool White.

⑥ Effect

Lighting effects mode can only be accessed through the APP. This mode offers 12 kinds of simulated light effects: Lightning, CCT Loop, Candle, Bad Bulb, TV, Paparazzi, Explosion, Pulsing, Strobe, Fire, Fireworks, and Welding.

APP CONTROL

APP Download Method

(Scan the QR code on the back of the manual to download the APP)

Android Device: Official website QR code, Google Play, Huawei Store, etc.

iOS Device: App Store

Device-adding

1. Before adding a device, please make sure you have turned on your phone's Bluetooth and network data, accessibility to Bluetooth and network data, then reset the lighting device's Bluetooth.
2. Click the "Add Device" button on the "My Devices" page to find the Bluetooth light devices that have been turned on nearby. (Figure 1)
3. Select the device to be connected for pairing. (Figure 2)

* Android requires location permissions to be turned on in order to connect your device using mesh technology, and we do not collect any of your location information during this process.

Device Management

1. After successfully adding your lighting device, your device will be displayed in the "My Devices" list. (Figure 3)
2. Click on the Device to access the device control. (Figure 4)

Figure 1

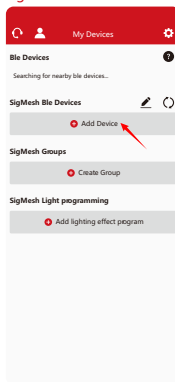

Figure 2

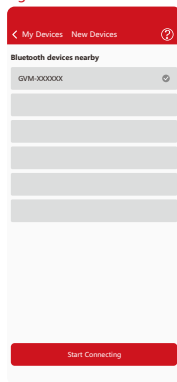

Figure 3

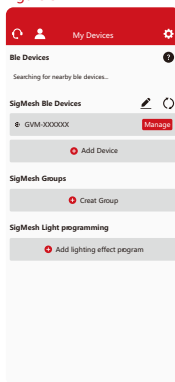
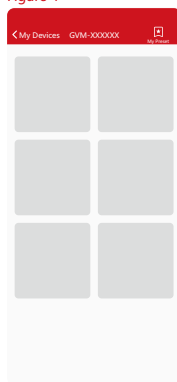

Figure 4



Account Login

- ◆ Use e-mail to get the verification code to log in (the first login automatically registers the account). (Figure 5)
- ◆ There may be a delay in sending the verification code, and the speed of delivery depends on the e-mail server you are using.
- ◆ Some email servers may recognize our verification emails as advertising promotions, please check your spam folder/inbox.
- ◆ After logging in, you can synchronize the Mesh Bluetooth devices bound to the current account to other smart devices.

Figure 5

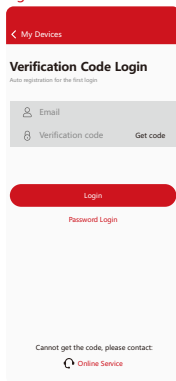

USE AND PRESERVATION

Do not place the product in a high humidity, strong electromagnetic field, direct sunlight, or high-temperature environment. If the product will not be used for a long time, please disconnect its power and remove the battery.

Cleaning: Unplug the power before cleaning. Use a dry cloth only—avoid cleaning agents or solventbased liquids, as they may damage the surface.

Power: Make sure the power is within the demanded range, not too high or too low. Correctly load the battery, in order not damage to the machine.

Repairing: If there is a fault or performance degradation, do not unpack the shell by yourself, avoiding damage to the machine and losing the right of maintenance. When there is a fault, do not hesitate to contact us, and we will do our best to deal with the problem.

Accessories: Please use the accessories provided by the manufacturer and approved ones, to maximize the performance.

Warranty: Do not modify the product, or you will lose the right to maintenance.

QUICK TROUBLESHOOTING

Issue	Check the product	Troubleshooting
The indicator does not light up.	Whether the connection between the light and the power supply is normal.	Make sure the adapter is well connected with the power plug.
While using the APP to add a device, the Bluetooth of the device cannot be found.	Check if the device is turned on properly and that it is not already paired by someone else connection.	Follow these steps: 1. Turn on phone's Bluetooth and network data function, android devices need to turn on the GPS positioning. 2. Allow access to Bluetooth and network data, GPS positioning. 3. Reset the device Bluetooth according to the user manual.
The APP failed to pair to a device.	Check if the device is turned on properly and has not been connected or paired by others; Check if the Bluetooth and network conditions of the cell phone are good.	Reset the device Bluetooth and restart the app then try to connect again.
The device is no longer searchable after removing it from the APP.	Check if the device have been removed while it is off-lined or in poor network conditions.	Reset the device Bluetooth and then search again to add the device.
In-app device controls can not be accessed.	Check if the device is online; If it's off-line, please advice to the Distribution Network Connection Failure steps.	Reboot the device, wait for 5 seconds, wait till it shows as online status. To control it; Reset the device Bluetooth and then add the device back to the device list.

PACKING LIST

Name	Quantity	Notes
ZipTile Z100B	1	
Controller	1	
Power Adapter	1	
Power Cord	1	
Diffusion Fabric	1	
Rail-Mount Baby Pin Adapter	1	
Swivel Yoke Mount	1	
V-Mount Rail Engagement Bracket	1	
Carrying Bag	1	

PRECAUTIONS

1. Please use the matching power adapter or lithium battery with the same specification to power the product. Do not use power adapter with different output voltage parameters.
2. The product is not waterproof, please use it in a rainproof environment.
3. The product is not anti-corrosion, therefore do not let the product touch any corrosive liquid.
4. When using the product, make sure the product is put firmly and prevents falling and damage.
5. If the product will not be used for a long time, please switch off the power to reduce energy loss.

PRODUCT WARRANTY

Dear user, this warranty card is important proof for applying for warranty service. Please cooperate with the salesperson to fill it out and keep it properly. Thank you!

Product Information	Model Number	Product Barcode
User Information	Name	Contact Number
	Mailing Address	
Seller Information	Name	
	Contact Number	
	Mailing Address	
	Sales Date	
Remarks		

Note: this form should be confirmed by the salesperson's stamp.

Applicable Products

This document applies to the products listed in the relevant "Product Warranty Information" (see instructions below). Other products or components that do not fall within this scope (such as promotional products, gift items, and other components added after the factory) are not covered by this warranty promise.

Warranty Period

The corresponding warranty period for products and components shall be executed according to the relevant "Product Warranty Information". The warranty period starts from the first day of purchase of the product, and the date of registration on the warranty card at the time of purchase shall prevail.

How to Obtain Warranty Service

You can directly contact the product salesperson or authorized service agency, or call GVM's after-sales service hotline to contact us and have our service personnel arrange service for you. When applying for warranty service, you should provide a valid warranty card as a warranty certificate to be eligible for warranty service. If you cannot provide a valid warranty card, we may also provide you with warranty service under the circumstance that our products or components are confirmed to be within the warranty scope, but this is not our obligation.

Cases where warranty does not apply:

If the product meets the following conditions, the warranty and service under this document will not apply:

1. The product or parts have exceeded the corresponding warranty period.
2. Malfunctions or damages caused by incorrect or improper use, maintenance, or storage, such as improper handling, use for purposes other than the reasonable expectations of the product, incorrect insertion or removal of external devices, falling or crushing due to external force, or exposure to inappropriate temperature, solvents, acids, alkalis, water immersion, or damp environments.
3. Malfunctions or damages caused by unauthorized installation, repair, modification, addition, or disassembly by institutions or personnel not authorized by GVM.
4. Modifications, changes, or removals of the original identification information of the product or its parts.
5. Lack of valid warranty card.
6. Malfunctions or damages caused by the use of unauthorized, non-standard or non-publicly released software.
7. Malfunctions or damages caused by force majeure or accidents.
8. Other malfunctions or damages not caused by quality issues of the product itself. In such cases, you should seek solutions from the relevant responsible parties, and GVM will not be held liable. Malfunctions or damages caused by components, accessories, or software not covered by the warranty or beyond the warranty scope that renders the product unable to function properly are not covered by the warranty. Fading, wear, and consumption that is normal during the product usage process are not covered by the warranty.

Product Warranty and Service Support Information

The product warranty period and service types are implemented according to the following "Product Warranty Information" for each product category, component, and optional equipment:

Product Category	Accessories Name	Warranty Period(Month)	Warranty Service Type
Component	Circuit Board.	12 Month	Customer service repair
Other	Spotlight mount, softbox, adapter, Standard reflector, power cord, battery Handle, light stand, TYPE-C cable, battery slot, battery, Fresnel lens, grid, carrying bag and all other accessories, etc. Consumable or electrically sensitive parts are not covered by the warranty.	None	No Warranty

QC
PASS



GVM Official website



Facebook



Download APP

Huizhou Latu Film Equipment Co., Ltd.

Web: www.gvmled.com

B&H Email: bh@gvmled.com

GVM Email: support@gvmled.com

Amazon Email: amazonsupport@gvmled.com

Warehouse Address: 12285 MCNULTY RD, STE 105 PHILADELPHIA, Pennsylvania 19154, USA