

GVM

TQ-M

CONTENTS

Product Introduction	Page 1
Disclaimers	Page 2
Product Details	Page 2
Product Structure Analysis	Page 3
Installation Method	Page 4~8
Function Introduction And Instruction For Use	Page 9~10
APP Playback Settings	Page 11~12
Use And Preservation	Page 12
Precautions	Page 12
Packing List	Page 13
Product Warranty	Page 14~15

PRODUCT INTRODUCTION

Welcome to use "TQ-M", this product is specially created for senior photography enthusiasts, the product can solve the problem of forgetting words and wrong words in live broadcast / studio photography / YouTube video shooting, making the broadcast more relaxed and natural.

The main features of the product are:

1. The base and bracket made of aluminum alloy make the equipment both light and strong.
2. The whole set of equipment adopts a simple and user-friendly hand-twisted screw structure, which is quick to install and has a multi-position installation method. The distance between the camera/tablet clip/mobile phone clip and the mirror screen and the camera height can be adjusted as needed. The operation is simple and the control is convenient.
3. Compatible with the installation of various photographic equipment such as SLR/digital.
4. The mirror plane adopts a colorless beamsplitter, a multi-layer dielectric coating (hard film) on the surface, no light loss, suitable for the various high-definition lens, wide-angle design, prompter document display is clear, no reflection, and no flaws will be exposed during shooting.

We firmly believe that the correct use of this product will definitely help your shooting work. Before using the product, we strongly recommend that you carefully read the following user guide.

DISCLAIMERS

1. Before using this product, please read the text carefully to ensure that the correct operation of the product has been carried out. Failure to follow and not following the instructions and warnings in this document may cause harm to you and others around you, or even damage the product or other surrounding items.
2. By using this product, you are deemed to have carefully read the disclaimer and warning, understand and acknowledge all the terms and contents of this statement, and promise to take full responsibility for the use of this product and the possible consequences.
3. Design and specifications are subject to change without notice.

PRODUCT DETAILS

- ◆ Brand : GVM
- ◆ Product model : TQ-M
- ◆ Product Type : Photography accessories
- ◆ Product Name : Teleprompter
- ◆ Product Weight : 2.2KG
- ◆ Product load : 10KG
- ◆ Product Size(mm) : 500×265×255
- ◆ Product material : Aluminum alloy
- ◆ Function / Feature :
 - ① Compatible with mobile phones and tablets.(within 10.5 inches)
 - ② Lightweight and easy to assemble and simple to operate.
 - ③ A variety of photography equipment including mirrorless cameras, SLR cameras, and camcorders can be used.
- ◆ Commodity origin : China. Huizhou

PRODUCT STRUCTURE ANALYSIS

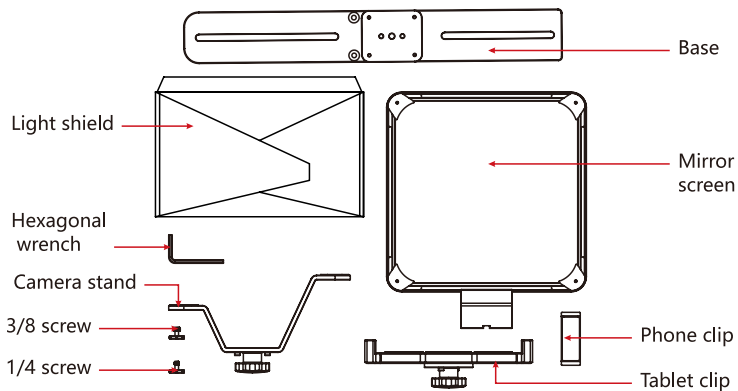

Before assembly

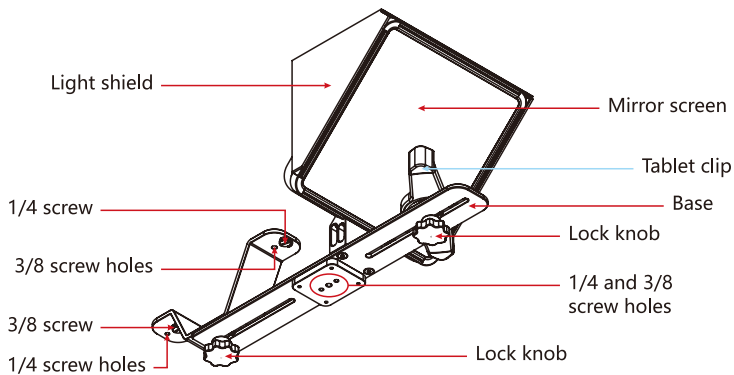

After assembly

INSTALLATION METHOD

- 1 As shown in the figure below, install the mirror screen on the base, and use the hex wrench to tighten the screws.

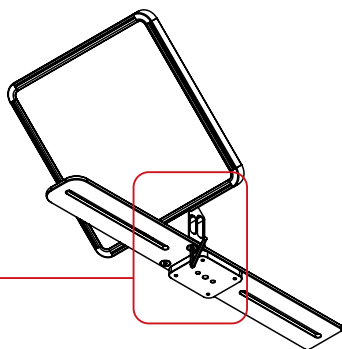
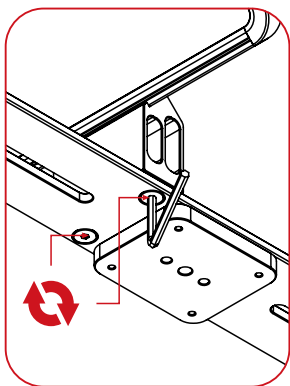
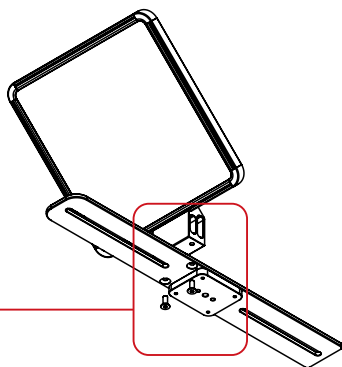
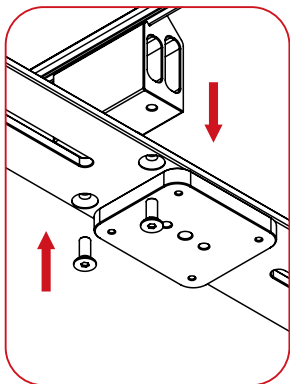

2 As shown below, install the teleprompter base to the tripod.

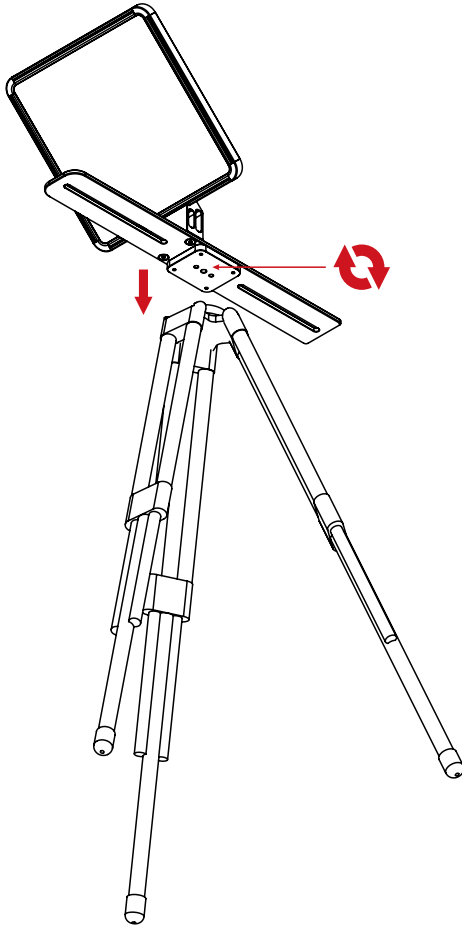

- 3** As shown in the figure below, attach the camera bracket to the base and tighten the locking knob. (The picture below shows the installation method of the camera stand front high rear low, you can also install the camera stand front low rear high).

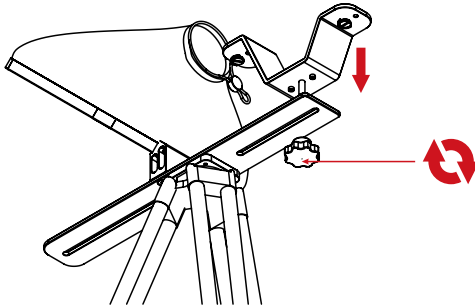

- 4** As shown in the figure below, the camera bracket is equipped with two camera mounts for height and height. Install the camera in the appropriate position according to the needs. Tighten the screw locking equipment (equipped with 1/4 screw and 3/8 screw each, the bracket also has 1/4 and 3/8 screw holes, choose the appropriate screw according to your needs).

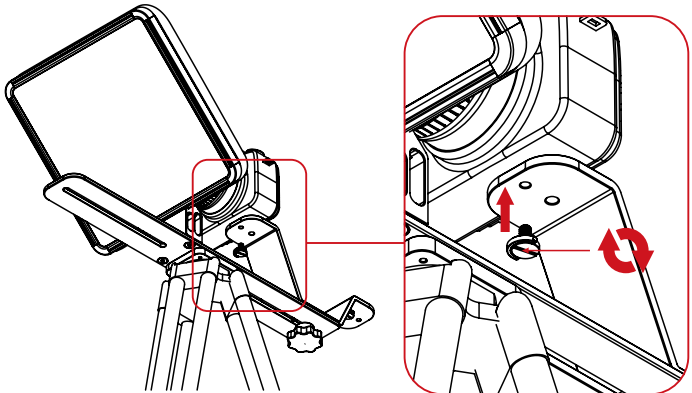

- 5** As shown below, put the shading cloth behind the mirror screen on the lens.

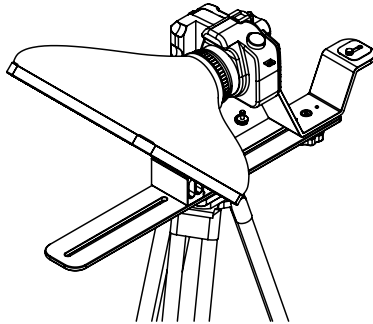

- 6** As shown in the figure below, install the tablet clip/phone clip to the base and tighten the locking knob.

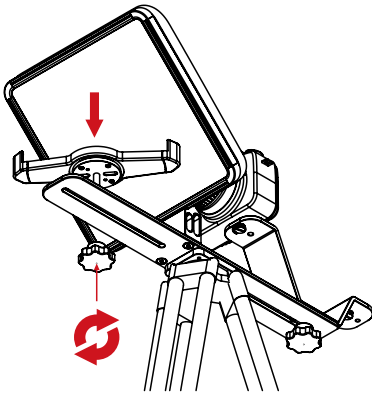

Tablet clip installation

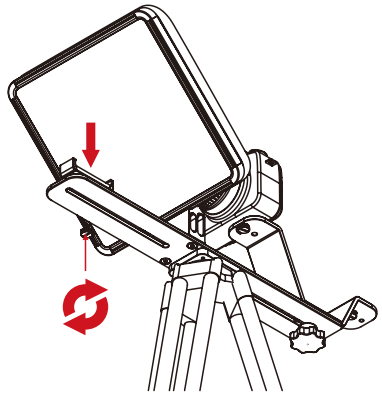

Phone clip installation

- 7** As shown in the figure below, pull the tablet/phone clip apart, and then install the tablet/phone.

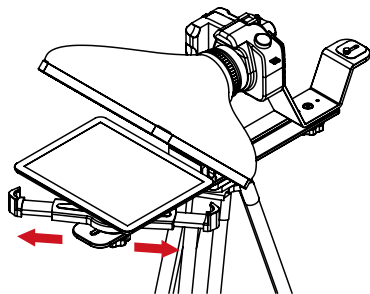

Tablet installation

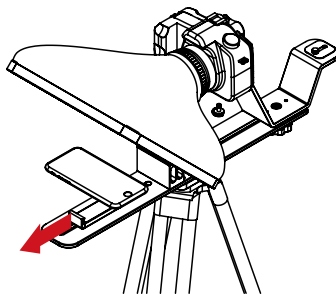

Mobile phone installation

- 8** As shown in the figure below, attach the shading plate to the mirror screen. At this point, the teleprompter is installed and you can shoot.

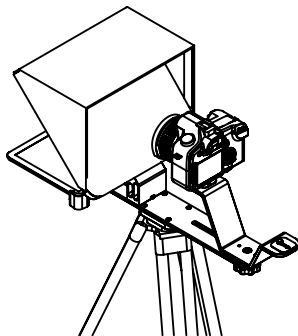
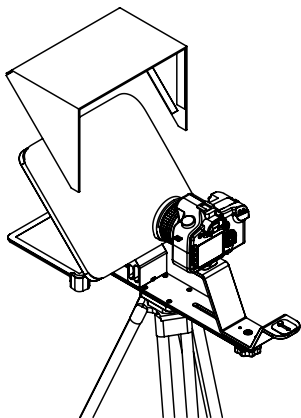

FUNCTION INSTRUCTION & INSTRUCTION FOR USE

① Reflect the content displayed on the tablet/phone :

The mirror screen can reflect the content displayed on the tablet/mobile phone below when the camera is shooting, so that the person who is photographed looks directly at the lens, and the content of the tablet/mobile phone can be seen in the mirror screen, which has a good mention for the person being photographed Function without affecting the shooting.

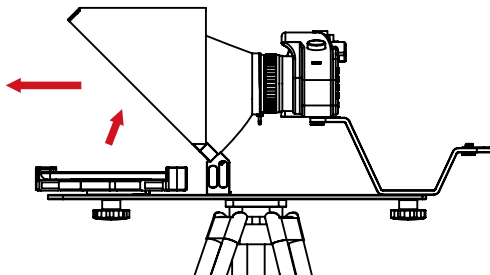

② Compatible with various photographic equipment :

Equipped with one each of 1/4 and 3/8 screws, and 1/4 and 3/8 screw holes on both ends of the photographic equipment bracket, you can install photographic equipment with 1/4 or 3/8 screw holes on the bottom (such as SLR, Cameras, digital cameras, DV machines, etc.).

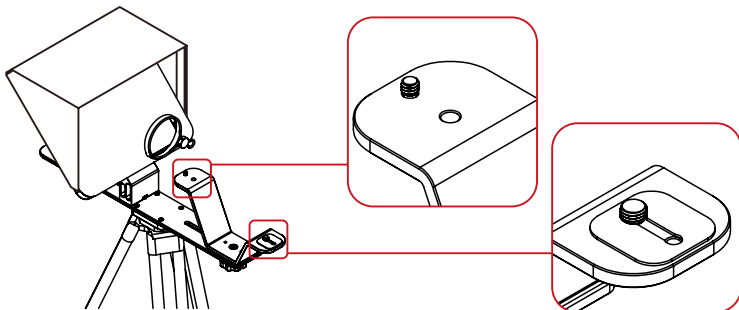

③ Easy to adjust :

The camera bracket has two equipment mounting seats for height, and the bracket can be installed as required. In addition, the distance between the camera bracket and the mirror screen and the distance between the tablet clip/mobile phone clip and the mirror screen can also be adjusted. It can be easily adjusted by releasing the lock knob under the bracket. After adjustment, tighten the lock knob.

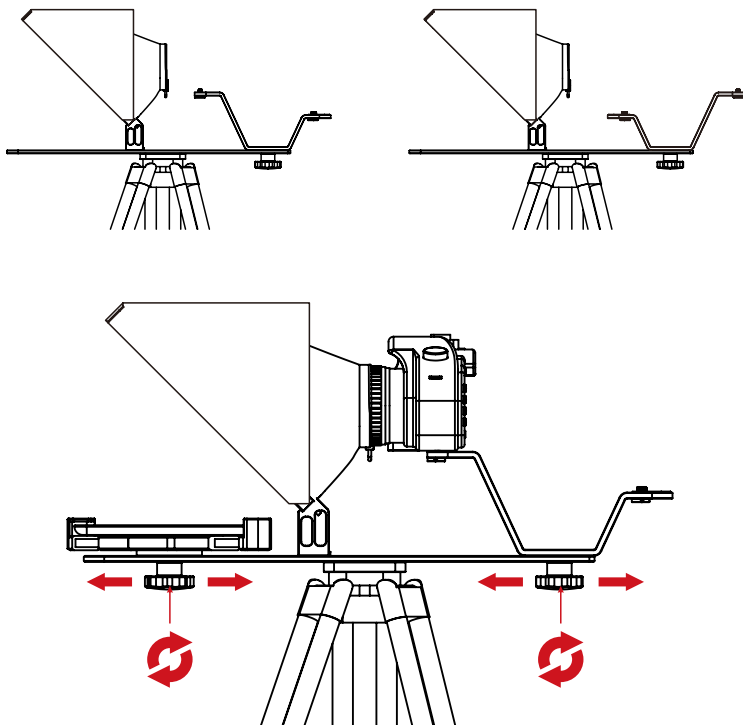

APP PLAYBACK SETTINGS

Scan the QR code on the back of the manual to download the APP

Open the "GVM Teleprompter" software on your mobile phone → enter the APP, you can use. The APP sets the content, font size, playback speed, background color and whether to mirror the prompt.

APP main interface

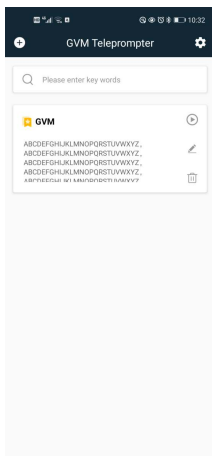

Setting interface

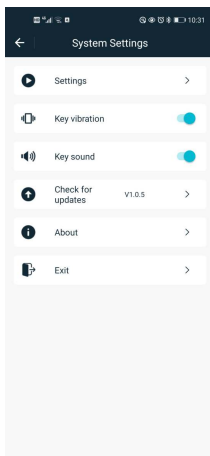

Playback settings Interface

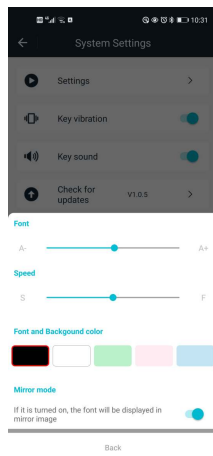

1. On the main interface of the APP, click " + " in the upper left corner to create a play file, you can choose "Add directly" is written on the APP, and can also import existing txt or Word files on the phone. The play file is created → a new play file appears on the main interface of the APP.
2. On the main interface of the APP, click on the right side of the file to be set:
 - " 🗑️ " Delete Files;
 - " ✎️ " Modify the content of the file;
 - " ▶️ " To enter the play interface → click " ⏸️ " on the play interface to start/pause the text; Click " ⋮ " in the lower right corner to set the font size, playback speed, and background when playing text. Color and whether it is mirrored; click on the " ⬅️ " in the lower left corner to return to the main interface of the APP.

1. On the main interface of the APP, click "⚙️" in the upper right corner to enter the setting interface → click on the play setting to enter the playback setting interface. Here you can also set the font size and broadcast, Play speed, background color and whether to mirror.

USE AND PRESERVATION

Do not store this machine in a highly humid environment with strong direct sunlight.

Cleaning: Please use a damp cloth to clean, do not use any detergent or solvent, otherwise it will damage the surface processing layer.

Maintenance: If the machine is faulty or its performance is degraded, please do not repair it yourself to avoid damage to the machine and loss of warranty rights. In case of machine malfunction, please contact us in time, and we will do our best for you.

Accessories: Please use the accessories provided by the manufacturer or approved accessory products in order to give full play to the best performance.

Warranty: This machine does not contain modifiable parts. Do not disassemble or modify, otherwise the warranty rights will be lost.

PRECAUTIONS

1. The product is not waterproof, please use it in a rainproof environment.
2. The product is not anti-corrosion, therefore do not let the product touch any corrosive liquid.
3. When using the product, make sure the product is put firmly and prevents falling and damage.

PACKING LIST

Name	Quantity	Notes
Base	1	
Mirror screen	1	
Camera stand	1	
Tablet clip	1	
Phone clip	1	
Light shield	1	
Hexagonal wrench	1	
1/4 screw	1	
3/8 screw	1	
User Manual	1	

PRODUCT WARRANTY

Dear user, this warranty card is important proof for applying for warranty service. Please cooperate with the salesperson to fill it out and keep it properly. Thank you!

Product Information	Model Number	Product Barcode
User Information	Name	Contact Number
	Mailing Address	
Seller Information	Name	
	Contact Number	
	Mailing Address	
	Sales Date	
Remarks		

Note: this form should be confirmed by the salesperson's stamp.

Applicable Products

This document applies to the products listed in the relevant "Product Warranty Information" (see instructions below). Other products or components that do not fall within this scope (such as promotional products, gift items, and other components added after the factory) are not covered by this warranty promise.

Warranty Period

The corresponding warranty period for products and components shall be executed according to the relevant "Product Warranty Information". The warranty period starts from the first day of purchase of the product, and the date of registration on the warranty card at the time of purchase shall prevail.

How to Obtain Warranty Service

You can directly contact the product salesperson or authorized service agency, or call GVM's after-sales service hotline to contact us and have our service personnel arrange service for you. When applying for warranty service, you should provide a valid warranty card as a warranty certificate to be eligible for warranty service. If you cannot provide a valid warranty card, we may also provide you with warranty service under the circumstance that our products or components are confirmed to be within the warranty scope, but this is not our obligation.

Cases where warranty does not apply:

If the product meets the following conditions, the warranty and service under this document will not apply:

1. The product or parts have exceeded the corresponding warranty period.
2. Malfunctions or damages caused by incorrect or improper use, maintenance, or storage, such as improper handling, use for purposes other than the reasonable expectations of the product, incorrect insertion or removal of external devices, falling or crushing due to external force, or exposure to inappropriate temperature, solvents, acids, alkalis, water immersion, or damp environments.
3. Malfunctions or damages caused by unauthorized installation, repair, modification, addition, or disassembly by institutions or personnel not authorized by GVM.
4. Modifications, changes, or removals of the original identification information of the product or its parts.
5. Lack of valid warranty card.
6. Malfunctions or damages caused by the use of unauthorized, non-standard or non-publicly released software.
7. Malfunctions or damages caused by force majeure or accidents;
8. Other malfunctions or damages not caused by quality issues of the product itself. In such cases, you should seek solutions from the relevant responsible parties, and GVM will not be held liable. Malfunctions or damages caused by components, accessories, or software not covered by the warranty or beyond the warranty scope that renders the product unable to function properly are not covered by the warranty. Fading, wear, and consumption that is normal during the product usage process are not covered by the warranty.

Product Warranty and Service Support Information

The product warranty period and service types are implemented according to the following "Product Warranty Information" for each product category, component, and optional equipment:

Product Category	Optional	Maintenance Period(Month)	Warranty Service Type
Component	Android integrated display screen	12 Month	Customer service repair
Other	Projection glass, Bluetooth remote control, lens hood , phone/tablet clip, storage bag, and all other accessories.	None	No Warranty

QC
PASS



GVM Official website



Facebook



Download APP

Huizhou Latu Film Equipment Co., Ltd.

Web: www.gvmled.com

B&H Email: bh@gvmled.com

GVM Email: support@gvmled.com

Amazon Email: amazonsupport@gvmled.com

Warehouse Address: 12285 MCNULTY RD, STE 105 PHILADELPHIA, Pennsylvania 19154, USA